

HARRIS CORPORATION

USER

MANUAL

TS21 CRAFT TEST SET
DESCRIPTION AND USE
NOVEMBER 1996

P/N 011-724892-001
Issue 1, November 1996

USER MANUAL

TS21 Craft Test Set Description and Use

November 1996



TS21 CRAFT TEST SET DESCRIPTION AND USE

CONTENTS	PAGE
1. GENERAL	1
2. DESCRIPTION	1
3. CONTROLS AND INDICATORS	2
4. CONNECTIONS	3
5. OPERATION	3
6. MAINTENANCE	4

WARNING

Good safety practices prohibit the connection of the TS21 and similar test sets to 117 volts AC commercial electrical power; and should the TS21 be connected to commercial power, all warranties are immediately voided.

1. GENERAL

1.01 The Harris Corporation's Dracon Brand TS21 Craft Test Set employs the latest technology in integrated circuit design to provide both DTMF (Touch Tone) and dial pulse output. The TS21 also provides last number redial, and field replaceable line cords and belt clips. This Test Set, often called a "butt-in," is a self-contained, line-powered, portable handset used by installers, repair technicians, and other authorized personnel for line testing and temporary communications.

2. DESCRIPTION

2.01 Physical Characteristics (Figure 1):

- (a) The housing (A) is injection molded of high impact polycarbonate which provides excellent insulating properties. The case is designed to give rugged service and withstand the rough handling and shocks normally associated with craft tools.
- (b) The back of the hand grip (B) is contoured and has a non-slip surface, freeing both hands while the Test Set rests on the shoulder.
- (c) The keypad (C) has 12 buttons on a black plastic bezel that is recessed into the receiver end of the housing. The recessed bezel provides physical protection to the keypad and prevents accidental button operation.
- (d) The spring-loaded belt clip (D), located on the transmitter end of the housing, ensures a secure connection to a belt loop or D-ring. The belt clip may be replaced in the field (see section 6.01).

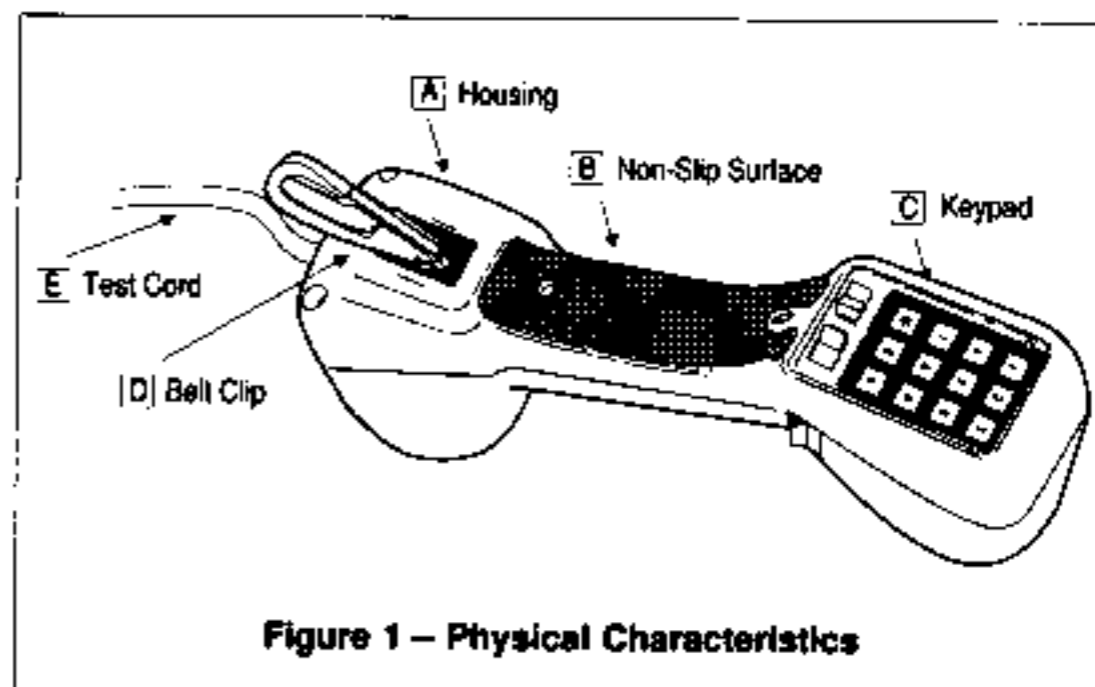

Figure 1 – Physical Characteristics

- (e) The test sets are equipped with several different cord configurations (E). The line cords may be replaced in the field (see sections 4 and 6.02).

2.02 Specifications:

(a) Electrical

Loop Limit	2 k Ω maximum at 48 VDC (nominal 20 mA minimum loop current)
DC Resistance (Talk Mode)	<300 Ω (similar to WECO 10131A and BECO 801)
Monitor Impedance	6 k Ω minimum at 1 kHz
Rotary Dial Output	
Pulsing Rate	10 pps + 0.5 pps
Percent Break	61% \pm 2%
Interdigit Interval	1000 ms typical
Leakage During Break	>50 k Ω
DTMF Output	
Tone Frequency Error	\pm 1% maximum
Level per Tone Pair	+1 dBm maximum -9 dBm minimum
High versus Low Tone Difference	4 dB maximum

(b) Physical

Length	9-11/16 inches (24.6 cm)
Width	2-11/16 inches (6.83 cm)
Height	3-11/16 inches (9.37 cm)
Weight	21 ounces (.600 kg) typical

(c) Environmental

Temperature	Operating: -34 to 60 $^{\circ}$ C Storage: -40 to 66 $^{\circ}$ C
Altitude	To 10,000 feet
Relative Humidity	5 to 95%

Specifications subject to change without notice.

2.03 Standard TS21 Models:

*Model No.	**Cord Type	Ground Start Switch
21800-081	STD	NO
21800-082	SBN	NO
21800-084	SP	NO
21800-087	3W	YES
21800-088	SPR	NO
21800-089	ABN	NO

*Special production models are indicated by a number in place of the zero following the "-"; -180, -281, -384, etc. These models are identical to their corresponding standard model, except for color and logo.

**See cord descriptions, Section 4.

3. CONTROLS AND INDICATORS

3.01 Voice and polarity controls (Figure 2):

(a) **Talk/Monitor (T/M) Switch.** This rocker switch is located on the side of the test set. The T (TALK) position establishes an off-hook condition for dialing and talking as a common battery telephone. The M (MONITOR) position removes the transmitter from the circuit, and provides a high impedance coupling to the line. The M position allows line monitoring without disrupting conversations, data, or signaling.

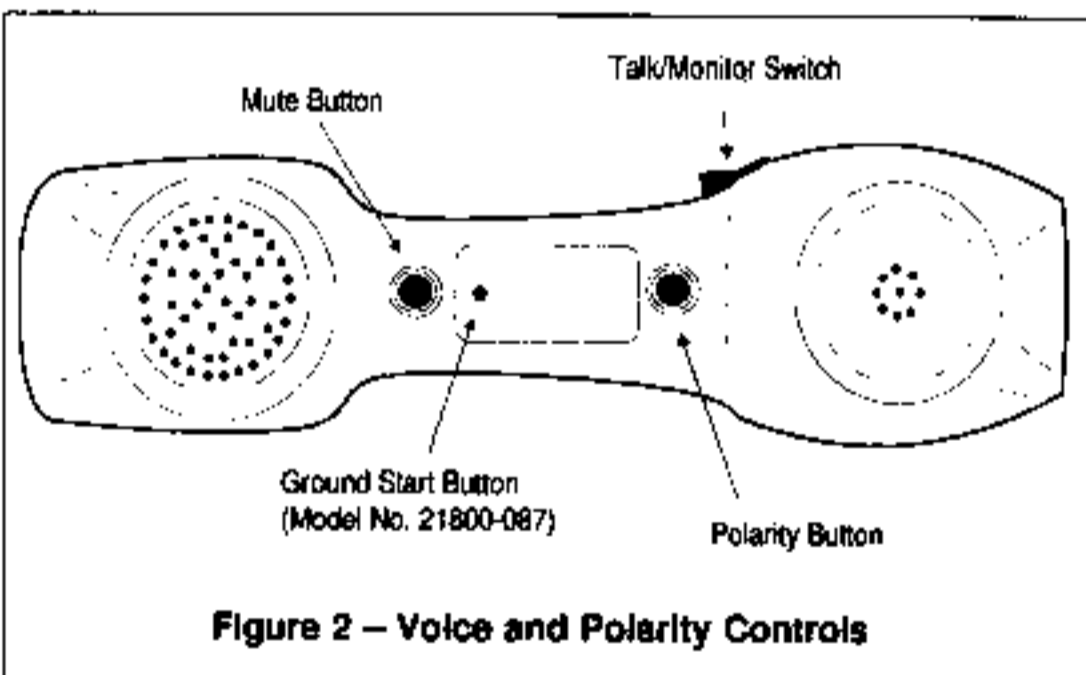

(b) **Mute (M) Button.** This non-locking push button, labeled M, is located on the inside of the hand grip just above the transmitter. When pressed, this button mutes the transmitter, eliminating sidetone, and providing improved intelligibility through the receiver in noisy locations.

(c) **Polarity Button.** This non-locking push button, labeled P, is located on the inside of the hand grip just below the receiver. When pressed, the button will activate one of the polarity LEDs, located at the top of the keypad, showing the current polarity of a telephone line or a low voltage battery source. See section 3.02(d).

(d) **Ground Start Button (optional).** Located between the MUTE button and the Polarity switch. When pressed, this small black button connects the ground (green) lead to the ring (red) lead of the special

three-conductor ground start cord, initiating a ground start line seizure.

3.02 Keypad Controls and Indicators (Figure 3):

(a) **Keys.** The 12 standard keys will send either DTMF tones or dial pulses, depending on the MODE switch setting. See (b).

(b) **MODE Switch.** This two-position locking rocker switch, labeled MODE, is located on the lower-right keypad bezel. The switch selects the signaling output: TONE for DTMF or PULSE for dial pulse.

(c) **Keypad Switch.** This two-position locking rocker switch, labeled KEYPAD, is located on the lower left keypad bezel. With the switch in the IN position, the Test Set operates as a telephone; this mode is used for all normal communications. The OUT position bypasses the Test Set circuitry, including the keypad. In this mode, signaling is not possible, but the TS21 will operate at very low voltages, much like standard Test Sets currently in use. The OUT position is recommended when testing at or near the loop limit (2,000 ohms at 48 volts DC), or when testing on dry circuits. The OUT position must be used when the circuit voltage is six volts or less, such as when using tones or other test devices as a source of talk battery.

(d) **Polarity LEDs.** These round LEDs, one green and one red, are located at the top of the keypad. One LED will illuminate when the polarity button is pressed, to indicate line polarity. See section 5.02. The green LED will light if the red test lead is connected to the ring (negative) side of the line and the black test lead is connected to the tip (positive) side of the line. The red LED will light if the test leads are reversed; that is, with the red test lead connected to the tip (positive) side and with the black test lead connected to the ring (negative) side.

CAUTION: Operation of the P button on a busy circuit may cause annoying clicks or service interruptions.

(e) **Last Number Dialed (#) Button.** The # (pound) key serves as a last number dialed button when the

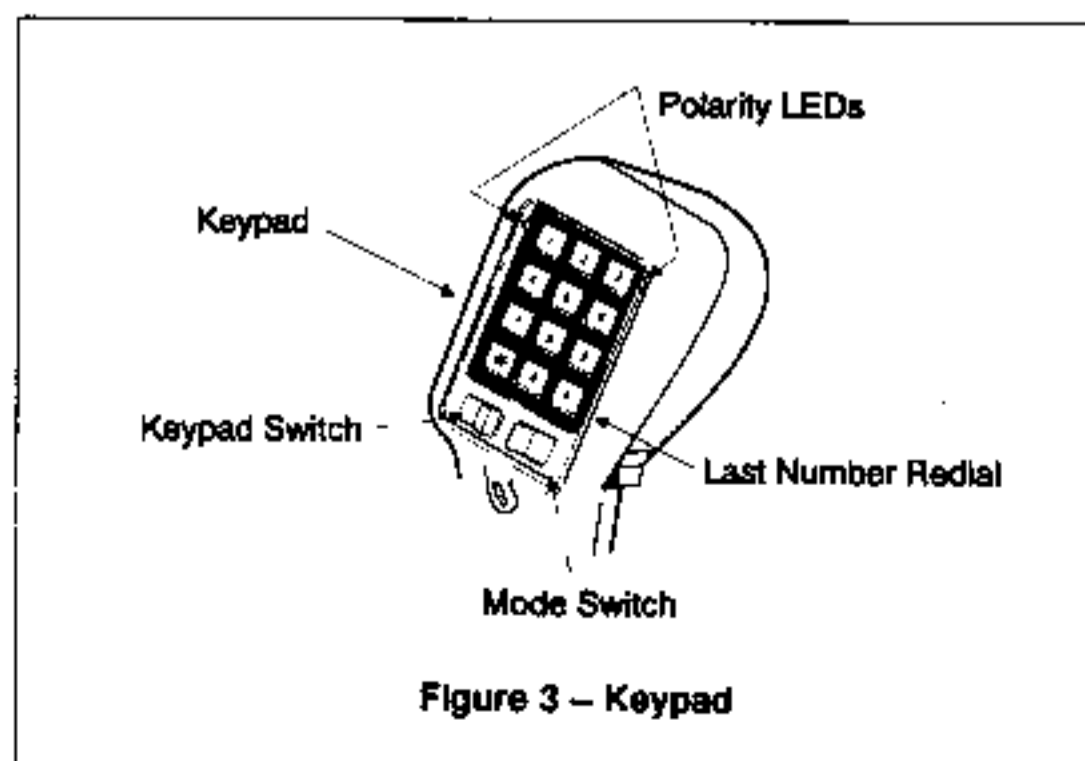

Figure 3 - Keypad

MODE switch is in the PULSE position. Pressing the # key will redial the last number dialed.

Note: The redial memory has a two minute time limit after the TS21 has been disconnected from a working telephone line. After two minutes, the number will be lost from memory.

4. CONNECTIONS

4.01 Cords (Figure 4):

(a) **Standard Cord with Piercing Pin (STD).** This cord consists of one red and one black conductor, each approximately five feet long. Each conductor is fitted with an alligator clip offset 20° to minimize clip shorting. The clips have insulation piercing spikes and a neoprene boot. Cord Number: P3218-028.

(b) **Angled Bed-of-Nails Cord (ABN).** The angled Bed-of-Nails cord is similar to the STD cord, except that each alligator clip is equipped with a "bed-of-nails" in addition to the insulation piercing spike. Cord Number: P3218-234.

(c) **Central Office Plug Cord (SP).** This cord is fitted with a type 346A female plug and is approximately one foot long. The plug allows the use of a variety of different test cords equipped with the matching 471A male connector. Cord Number: P3218-232.

(d) **Central Office Plug and Resistor Cord (SPR).** This cord is fitted with a type 346A female plug and switchable 1500 ohms resistor, and is approximately 18 inches long. When switched on, the resistor is inserted in series with the ring side of the cord to simulate a long loop condition. The plug allows the use of a variety of different

test cords equipped with the matching 471A male connector. Cord Number: P3218-233.

(e) **Bed-of-Nails Cord (SBN).** This cord is identical to the standard (STD) cord, except that each alligator clip is equipped with a bed-of-nails in addition to an insulation piercing spike, and the clips are not offset as are the STD clips. Cord Number: P3218-024.

(f) **Ground Start Cord (3W).** This cord consists of one red, one black, and one green fabric covered tinsel conductor approximately five feet long, each fitted with an alligator clip of the type used on the standard cord. Pressing the GROUND START button connects the green (ground) conductor to the red (ring) conductor inside the Test Set. Cord Number: P3218-025.

5. OPERATION

5.01 Monitoring. Move the T/M switch to M (KEYPAD IN/OUT and MODE switches may be in either position), and connect the line leads to the telephone line under test. Monitoring may now be done without disrupting traffic.

Note: The TS21 is not polarity sensitive and will function normally regardless of telephone line polarity.

5.02 Polarity Check. Move the T/M switch to M. Connect the line leads to the telephone line under test. Verify that the telephone line is idle. Press and hold the depressed P button. The green LED will light if the red test lead is connected to the ring (negative) side of the line and the black test lead is connected to the tip (positive) side of the line. The red LED will light if the test leads are reversed; that is, with the red test lead connected to the tip (positive) side and with the black test lead connected to the ring (negative) side.

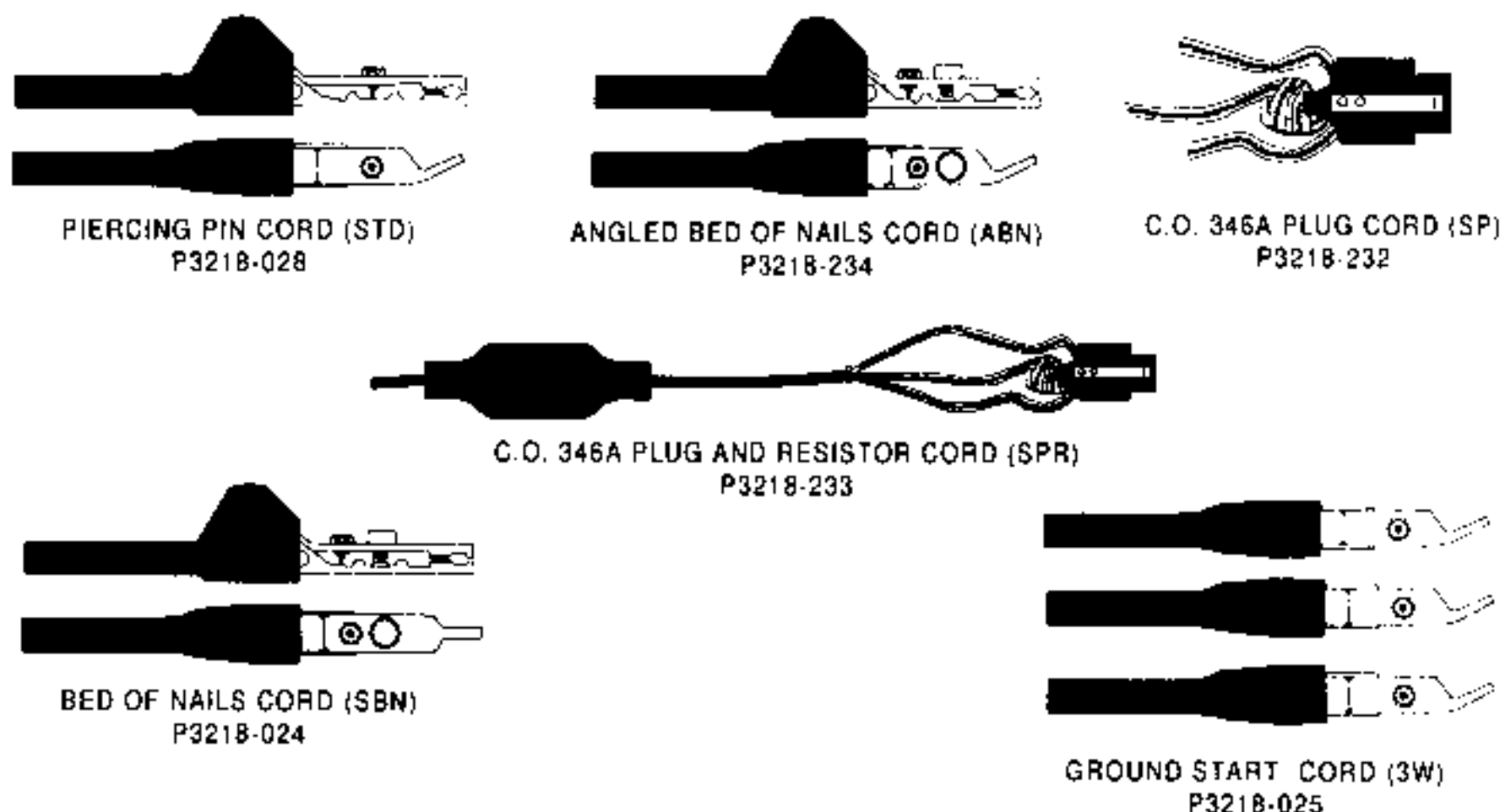

Figure 4 - Cords

CAUTION: Operation of the POLARITY button on a busy circuit may cause annoying clicks or service interruptions. Operation of the switch on an idle telephone line may cause telephone line seizure.

5.03 Dialing.

- (a) Move the KEYPAD switch to the IN position. Move the MODE switch to either TONE or PULSE, depending on the type of dial signaling required. Move the T/M switch to the M position. Connect the line cord clips to the telephone line. Listen to verify that the telephone line is idle.
- (b) Move the T/M switch to T position and verify that dial tone is received (when furnished). Enter the desired number to be called on the keypad. If tone signaling has been selected, the tones associated with each digit will be generated as each respective button is pressed. If rotary dial pulse signaling has been selected, the desired number may be entered at any rate on the keypad; digits will automatically be pulsed out at the correct rate. To end the call, return the T/M switch to the M position.

5.04 Last Number Redial. Move the MODE switch to the PULSE position. The last number dialed can be automatically redialed by using the following procedure (the number cannot exceed 18 digits):

- (a) Go on-hook (move the T/M switch to the M position) for at least 1/2 second.
- (b) Move T/M switch back to T position.
- (c) Press the # (pound) key and the number will be automatically redialed.

In the off-hook mode, if any key other than the # button is pressed, the previously stored number will be erased.

Note: The redial memory has a two minute time limit after the Test Set has been disconnected from a working telephone line. After two minutes, the number will be lost from memory.

5.05 Ground Start Line Seizure (optional). Pressing the GROUND START button connects together the ground (green) and ring (red) leads of the three-conductor test cord.

5.06 Operation On Low Voltage or Dry Circuits.

- (a) Move the keypad switch to OUT. This position bypasses the circuitry of the Test Set and increases the loop limit. The keypad will not operate in this mode, but all other functions operate normally.
- (b) Move the T/M switch to M. Connect line leads to the circuit under test. Verify that the circuit is idle. Move the T/M switch to T for two-way communications.
- (c) When operating on low voltage or dry circuits, a minimum of three volts DC talking battery is required.

5.07 Troubleshooting. The following troubleshooting procedures are based largely on the audible *click* heard in the receiver of the TS21 when the two Test Set leads are placed on battery potential and ground respectively, or across the terminal of an electrically charged capacitor. These *clicks* and other sounds can greatly help a skilled crafts person in locating open circuits, shorts, crosses, and grounds.

- (a) To locate a short circuit, open one side of the telephone line and place the test set in the loop— one lead to each side of the opened line. On the CO side of the fault, a loud *click* will be heard; on the field side of the fault, **no click** will be heard.
- (b) Locating an open circuit is done by bridging the test set across the circuit line — one test lead on tip, the other on ring. Moving away from the CO, the fault is at the point where the loud *click* disappears.
- (c) Continuity of each side of the loop may be verified by placing one of the line leads on a local ground and the other on the conductor in question. On a good ring conductor, a *click* will be heard; on a good tip conductor, an inductive *hum* will be heard (due to the difference in ground potential between the CO ground and the local ground).

Note: For a full discussion on these troubleshooting procedures, refer to your company's practices, or to *ABC of The Telephone, Volume 2*, Chapters 13, 14, and 15.

CAUTION: When testing circuits that are relatively close to the battery source, the clicks may be loud enough to cause temporary acoustical shock if the receiver is held too tightly against the ear. The TS21 is designed to rest comfortably on the shoulder with the receiver away from the ear. It should be used in this position when listening for clicks.

6. MAINTENANCE

6.01 Belt Clip Replacement. The belt clip may be easily replaced in the field without opening up the Test Set. The ordering number for the replacement belt clip is P3218-249. To replace the belt clip assembly:

- (a) Place the Test Set on a firm and level working surface with the keypad up.
- (b) Move the clip of the belt clip into an upward position to expose the two mounting screws, and remove the screws. Remove and discard the old belt clip.
- (c) Position the new belt clip so that its screw mounting holes line up with the mounting holes in the Test Set. Insert the screws and tighten.

Note: Be careful not to over tighten.

6.02 Line Cord Replacement. The line cord may be replaced in the field by experienced personnel, as the

Test Set must be opened up exposing its electronic circuit boards.
To replace the line cord:

- (a) Place the Test Set on a firm and level working surface with the keypad up.
- (b) Remove the five housing screws, located:
 - One above the keypad,
 - One below the keypad on the hand grip,
 - One above the belt clip on the hand grip, and
 - Two on either side of the belt clip.
- (c) Carefully separate the upper housing from the lower housing.

CAUTION: When separating the two housings, be careful of the connecting leads between the two housings. Place the two housings side-by-side, with the keypad and transmitter-receiver sides down, to minimize any strain on these leads.

- (d) Remove the two line cord lead screws on the circuit board, near the belt clip end. Gently pull the cord free of any obstructions. Remove and discard.
- (e) Position the individual lead tips of the new line cord so that the tips line up with the screw holes in the circuit board. The red lead to the right screw, labeled R (Ring), and the black lead to the left screw, labeled T (Tip). Insert the screws and tighten.

Note: Be careful not to over tighten the screws.

- (f) Position the brass line cord strain relief bushing or ring on the line cord so that it is inside the housing and lines up with the line cord exit hole.
- (g) Carefully close the two housings together, being careful not to pinch any of the wires. Insert the five housing mounting screws, and tighten.

Note: Be careful not to over tighten the screws.

Warranty

6.03 Harris Corporation warrants that the test set unit shall be free of any defects in parts or workmanship, for a period of 18 months and the line cord for a period of twelve (12)

months from the date of manufacture, if used under Harris operating specifications.

THIS IS THE ONLY WARRANTY MADE BY HARRIS CORPORATION AND IS MADE EXPRESSLY IN LIEU OF ALL OTHER WARRANTIES EXPRESS OR IMPLIED, INCLUDING BUT NOT LIMITED TO ANY IMPLIED WARRANTIES OF MERCHANTABILITY OR FITNESS FOR ANY PARTICULAR PURPOSE.

Should any parts or workmanship prove defective, Harris Corporation will repair with not used or reconditioned parts, or replace the Product, at Harris' option, at no cost to the Buyer except for Shipping costs from the Buyer's location to Harris' location. This is the Buyer's **SOLE AND EXCLUSIVE REMEDY** under the Agreement.

All incidental or consequential damages shall be excluded.

6.04 This warranty does not extend to products which have been subjected to neglect, accident or improper use, nor to units which have been altered or repaired by other than authorized Harris Corporation personnel.

Return Of Equipment

6.05 To return the Test Set to Harris, first obtain a Return Authorization Number from our Customer Service by calling 1-800-437-2266. This Return Authorization number must be clearly marked on the shipping label, or the container will not be accepted by Harris. See the sample label below:

To: HARRIS CORPORATION
809 Calle Plano
Camarillo, California 93012-8516
Attention: Customer Support, RA #XXXXXX

CAUTION: Do not use CRC Cable Clean® or any similar chlorinated solvent on the TS21. Doing so will damage the test set.