

CHANNEL VISION Limited Warranty

Channel Vision Technology will repair or replace any defect in material or workmanship which occurs during normal use of this product with new or rebuilt parts, free of charge in the USA, for two years from the date of original purchase. This is a no hassle warranty with no mail in warranty card needed. This warranty does not cover damages in shipment, failures caused by other products not supplied by Channel Vision Technology, or failures due to accident, misuse, abuse, or alteration of the equipment. This warranty is extended only to the original purchaser, and a purchase receipt, invoice, or other proof of original purchase date will be required before warranty repairs are provided.

Mail in service can be obtained during the warranty period by calling (800) 840-0288 toll free. A Return Authorization number must be obtained in advance and can be marked on the outside of the shipping carton.

This warranty gives you specific legal rights and you may have other rights (which vary from state to state). If a problem with this product develops during or after the warranty period, please contact Channel Vision Technology, your dealer or any factory-authorized service center.

CHANNEL VISION™

Model ID850

Dual Voice Coil In-ceiling Speaker

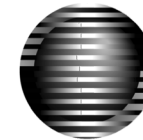
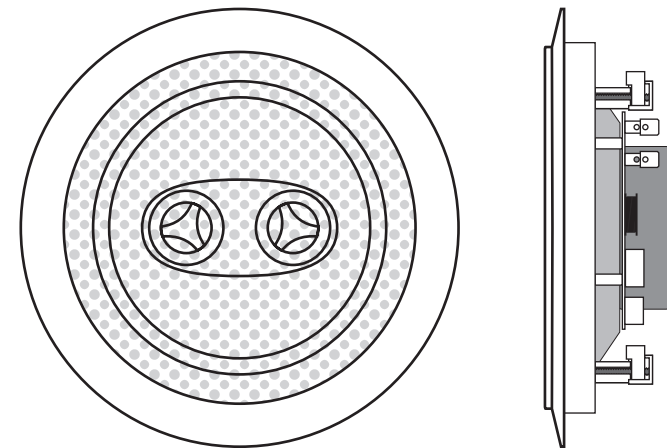

CHANNEL VISION™

234 FISCHER AVENUE • COSTA MESA, CA 92626
(714) 424-6500 • (800) 840-0288 • (714) 424-6510 fax
www.channelvision.com • email: sales@channelvision.com

Model ID850

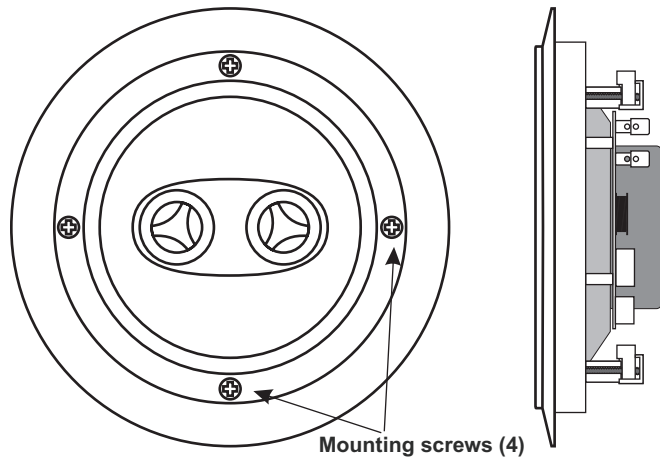

Installation:

- Use the included template to mark and cut an 8" hole in drywall away from ceiling joists.
- We recommend wiring with AWG 16 or larger, stranded wire.
- For proper phasing, both voice coils must be wired alike. Connect red wires to red terminals on speaker and to red or plus terminals on amplifier.
- Install ID850 in hole. Tighten the mounting screws. The mounting dogs will rotate outward and grip the drywall.
- Aim tweeters
- To control the volume of the speaker locally, use an impedance matching volume control, such as the Channel Vision VC300.

Features:

- Dual voice coil speaker delivers stereo sound from a single speaker
- Use when only one speaker will fit or to balance coverage in a whole house audio system
- Use in bathrooms, hallways, entry ways
- 8" Mica-filled polypropylene woofer with true rubber surround
- Dual ½" fluid-cooled ultra-wide dispersion mylar tweeters
- Tweeters swivel independently up to 45 degrees
- Tweeter protection using thermal sensing polymer switches
- 18 dB/octave crossover network
- Mounting template and paint shield included
- Recommended power: 5W to 100W

Specifications:

Frequency range:	55Hz - 20kHz ± 3dB
Sensitivity:	90dB
Power Handling:	75 Watts/channel (RMS)
Drivers:	2- ½" Mylar dome tweeter 1- 8" polypropylene woofer
Impedance:	8 ohms
Finish:	ABS plastic
Dimensions:	10¾" OD. 4" height (from surface of wall board)
Weight:	5 Lbs as shipped

Specifications subject to change without notice.